



Perfect METTCAST LIMITED

ISO 14001 : 2015 & IATF 16949 CERTIFIED



Global Manufacture & Suppliers of
Fasteners And Sheet Metal Components

ANCHOR BOLT L & J • THREADED ROD • TIE ROD • HEX BOLT
HEX NUT • WASHERS • U- BOLT • PIPE CLAMP • PIPE SUPPORT
SCAFFOLDING ACCESSORIES • CHAINLINK FENCING ACCESSORIES



PERFECT METTCAST LIMITED

From modest beginning of manufacturing Casting and scaffolding components in 2006, Perfect Mettcast Ltd. has emerged as the industry leader in Scaffolding Components, Sheet Metal, Casting & Forged Components. The Dramatic Evolution of our Company is grounded on the simple principle together with capacity expansion leads us to debut PML brand. Decades of our efforts have won an excellent Global Reputation.

The efficient Manufacturing setup professional excellence results in resounding success with a zeal to do the best. Our benchmark is manufacturing process against the best in the industry to create the most innovative product design, compiled with our stringent quality standards and testing method. We endeavour to ensure reliability and consistency throughout the manufacturing process.

The company is backed by the promoters who have a vast experience in the trade for more than three decades. Perfect Mettcast Ltd. has highly motivated and Qualified Team of Professionals working endlessly to ensure that the customers of the company are provided which are of the top most Quality. The combination of professionalism, latest technology and experienced promotors ensure that products developed and Distributed by Perfect Mettcast Ltd. are rated amongst the best in the industry.

Perfect Mettcast Ltd. is striving to achieve perfection in all its endeavours and would go an extra mile in order to achieve the best results. The whole team is working endlessly to ensure that the company motto "Building Relationship through Quality" is achieved in its fullest in all respects.

PML Group is engaged in manufacturing and export of engineering goods by the process of Sand Casting (Grey Iron & SG Iron, MS & En8), Aluminum high pressure die casting & machined components to domestic and overseas customers Sheet Metal, Forgings Parts, Scaffolding Parts and Fasteners, with Annual turn Over of 30 Million USD

Perfect Mettcast Ltd. is bagged with IATF-16949: Certification from TUV. Quality is the utmost constituent of Our products as we consider quality as the integral part of our manufacturing process and not as the routine of final check.

CERTIFICATE



ISO 14001 : 2015



IATF 16949

Our Mission is to be a Global company providing Total Business Solutions through Quality Products, Systems & Services in the field of Automobile, Railway, Mining, Construction & other Potential areas.

QUALITY POLICY

The strength of PERFECT METTCAST LTD. is based on the skills, professionalism and dedication of its staff, ensuring high-quality consciousness, checking all products periodically. Automation of Export department. likewise plays an important role in providing prompt information. Besides the company guarantees high quality of products, it is committed to deliver efficient customer service too. The company also ensures execution of orders and supply within stipulated time.

PERFECT METTCAST LTD. has successfully implemented 5-S. The policy of PERFECT METTCAST LTD. is to establish and implement strategic controls and goals that will ensure continuous improvement of satisfaction for all customers. To this end the Senior Management sets goals (at annual and intermediate reviews) in Quality, Delivery, cost and Customer Perception. The management ensures that the quality objectives are established at relevant functions and level with in the organization. It is ensured that all- of- the employees activity participate in attaining the Management goals for Quality. Delivery and Cost and hence Customer Satisfaction.

The strength of PERFECT METTCAST LTD. is based on the skills, professionalism and dedication of its staff, ensuring high-quality consciousness, checking all products periodically. Automation of Export department. likewise plays an important role in providing prompt

INDEX

INDEX

S NO.	PARTICULARS	PAGE NO.
1	About US	02-03
2	Foundry	04-07
3	Aluminium Castings	08-09
4	U-Bolts	10-12
5	Fasteners & Sheet Metal Components	13
6	Anchor Bolts (Straight,L& J-Type)	14-15
7	U Bolts	16
8	Fully Threaded Rod	17
9	Pipe Clump	18
10	Hex Bolt & Nut	19-20
11	Washers	21
12	Chain Link Accessories	22
13	Scaffolding Accessories	23
14	Spring Pin	24
15	Plant and Infrastructure	25-26
16	Company Aerial View	27-28

Ferrous Foundry

Dual Track Induction Furnaces Make INDUCTOTHERM Capacity 1 Ton.
Dual Track Induction Furnaces Make INDUCTOTHERM Capacity 0.5 Ton.
Automated Sand Plant Make DISA Capacity 20 Tons/Hour.
Automated Moulding Machines Make DISA Capacity 700 X 600 X (300+300) mm Box and 500 X 500 X (250+250) mm
Shell Core Shooter from SUSHI Japan, No Bake core Making & CO2 Core Making.
Hanger Type Shot Blasting Machine Make DISA.
Fully Equipped Pattern Shop with all Modern Pattern Making Facilities.
In House Design Section with Design Tools Like DEL CAM, SOLID WORKS, AUTO CAD & CAM.
Modernized Laboratory with Spectrometer, Image Analyser & Metallurgical Microscope, Sand Testing Facilities.
In House Machining Facilities Equipped with VMC, HMC & CNC, VTL & SPM Machines.

Die Casting

250 TONS PDC MACHINES (2) with auto ladle/auto spray facility Make ZITAI.
350 TONS PDC MACHINES with auto ladle/auto spray facility Make SINATEK.
420 TON PDC MACHINES with auto ladle/auto spray facility make ZITAI, HMT – BUHLER, SINATEC.
Component up to 4 Kg.

Design Devolvement

Designing Section is equipped with following facilities:

CAD – Solid Works 2011
Uni Graphics
CAM – Delcam (Powermill 8)
AUTO CAD
Workstation HP XW-4600
Workstation LENOVO MT-M-6243
Flow Simulation – Procast from PSI

Tool Room

CNC Vertical Machining Centers Make HAAS, MAKINO, DMG.
CNC Turning Centers Make HAAS, DMG, ACE.
Radial Drill Machine Make BATLIBOI.
E D M Machine Make ELECTRONICA.
Surface Grinder Make PRAGA.

Machining

CNC (Computer Numerical Control) Machine make ACE, NAKAMURA, DMG, HITACHI, SEIKI & Nos. 15
VMC (Vertical Machine Center) Machines Make HAAS, ACE, MANKIND, DMG Nos. 13
HMC (Horizontal Machining Centre) machines make BRIDGE PORT, DMG & Nos. 2
VTL HITACHI

Welding Shop equipped with MIG, TIG & Electric Welding.
Eclectic Billet Heating Machine for Forging 100w: 03 No. , 150w : 04 No.
In-House Phosphate & Electroplating Plants.
Automatic Powder Coating Plant with up to 20 M.Ton Production in a Day.



Perfect
METTCAST LIMITED

ISO 14001 : 2015 & IATF 16949 CERTIFIED

Foundry





BRACKET

SR. NO.	TYPE	O.E.M
249	FRONT SPRING	346 322 5001
250		348 322 5001
251		352 325 8901
252		342 322 0001
253		348 322 0001
254	FRONT	355 325 0101
255		328 322 0001
256		352 322 7012
257		314 322 0003
258	FRONT	346 322 0101



BRACKET

SR. NO.	TYPE	O.E.M
259	BRACKET	395 325 1119
260		617 325 0001
261		387 325 0001
262	REAR	327 325 0001
263		353 322 0101
264		385 385 0001



SHACKLE

SR. NO.	TYPE	O.E.M
265	REAR	312 322 1620
266		346 325 0020
267		346 320 5063
268	FRONT (WITH BUSH)	617 325 0183
269	FRONT	314 322 0020
270		387 322 120
271		387 320 0162
272		314 325 0020



HELPER BRACKET

SR. NO.	TYPE	O.E.M
273	FOUR HOLE	352 325 0417 / 3893250117
274	SIX WHOLE	346 325 0020



WHEEL BRACKET

SR. NO.	TYPE	O.E.M
134	FORGING	659 002 171
135	CASTING	659 002 171



WHEEL BRACKET

SR. NO.	TYPE	O.E.M
136	FORGING	659 002 129
137	CASTING	659 002 129



WHEEL BRACKET

SR. NO.	TYPE	O.E.M
138	CASTING	659 002 215



WHEEL BRACKET

SR. NO.	TYPE	O.E.M
139	CASTING	659 002 217



WHEEL BRACKET

SR. NO.	TYPE	O.E.M
140	CASTING	659 002 101

SAND CASTING COMPONENTS



HANGER SHACKLE



BRACKET



CENTER BRACKET



ENGINE MOUNT BRACKET



ELECTRICAL POLE FITTINGS



ELECTRICAL POLE FITTINGS



ELECTRICAL POLE FITTINGS



ELECTRICAL POLE FITTINGS



ROTAVATOR GEAR BOX



PLATE COVER



NON- DRIVE CUP



WN FLANGE



PUMP SUPPORT BRACKET



SHAFT BRACKET



LINK SHAFT BRACKET



DIFF CASE



BRACKET RECEIVER FORK



PLANETARY CARRIER



DIFFUSER



MANIFOLD 3 CYLINDER

Aluminium Die Casting



ALUMINIUM CASTING COMPONENTS



AC COVER PLATE



AIR CYLINDER



PISTON



ALUMINIUM OIL TANK



TOP COVER



RG 2 BODY



BREAK PAD



FLANGE



OIL TANK BIG



TOP COVER



UPPPER BODY



TOP COVER



TOP COVER



DUAL BRAKE VALVE



TILT PUMP



FLANGE ASSEMBLY



FOOT BRAKE VALVE



SEED FEEDING DRILL PISTOLI



BREAK LEVER



NEW BREAK MASTER CYLINDER

U- BOLT WITH NUTS
BEST SUITABLE : MERCEDES



SR. NO.	TYPE	O.E.M
1	FRONT	3203310325
2	FRONT	3933310025
3	FRONT	3043311625
4	FRONT	3343310125
5	FRONT	3333310125
6	FRONT	3363310025
7	FRONT	3433310225
8	FRONT	3893310025
9	FRONT	3893310025
10	FRONT	3873310025
11	FRONT	3873310125
12	FRONT	3873310325

U- BOLT WITH NUTS
BEST SUITABLE : MERCEDES



SR. NO.	TYPE	O.E.M
13	REAR	
14	REAR	3953510125
15	REAR	
16	REAR	
17	REAR	3953350225
18	REAR	3953510225
19	REAR	3953510625
20	REAR	3953510325
21	REAR	3953510325
22	REAR	3953510425
23	REAR	
24	REAR	
25	REAR	
26	REAR	
27	REAR	

U- BOLT WITH NUTS
 BEST SUITABLE : MERCEDES



SR. NO.	TYPE	O.E.M
28	REAR	3933510125
29	REAR	3353510825
30	REAR	3353510025
31	REAR	3343510025
32	REAR	3353511325
33	REAR	6203510025
34	REAR	3363510425
35	REAR	3633510125
36	REAR	3873510025
37	REAR	3363510225
38	REAR	3463515025
39	REAR	3893510125
40	REAR	3893510225
41	REAR	3893510325
42	REAR	3893510325



U- BOLT WITH NUTS
 BEST SUITABLE : MERCEDES

SR. NO.	TYPE	O.E.M
43	REAR	
44	REAR	
45	REAR	
46	REAR	



U- BOLT WITH NUT
BEST SUITABLE : B.PW

SR. NO.	TYPE	O.E.M
47	SMALL	0313842010
48	SMALL	



U- BOLT WITH NUT
BEST SUITABLE : B.PW

SR. NO.	TYPE	O.E.M
49	BIG	0313861020
50	BIG	0313861070



U- BOLT WITH NUT
BEST SUITABLE : B.PW

SR. NO.	TYPE	O.E.M
51	REAR	
52	REAR	
53	REAR	
54	REAR	
55	REAR	
56	REAR	
57	REAR	

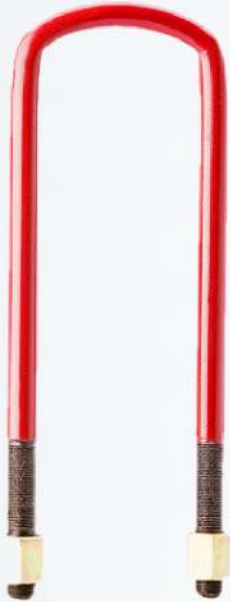

U- BOLT WITH NUT

BEST SUITABLE : B.P.W

SR. NO.	TYPE	O.E.M
58		81413120023
59		81413120081
60		81413120102
61		81413120218
62		81413120073
63		81413120201



U- BOLT WITH NUT

BEST SUITABLE : B.P.W

SR. NO.	TYPE	O.E.M
64	FRONT	15909419
65	FRONT	15909212
66	REAR	
67	REAR	02045698
68	REAR	941694
69	REAR	
70	REAR	
71	REAR	



Perfect
METTCAST LIMITED

ISO 14001 : 2015 & IATF 16949 CERTIFIED

Fasteners and Sheet Metal

“Perfect Mettcast Limited” (PML) is a well-known name in field of Fasteners like: ANCHOR BOLT “L & J” TYPE. THREADED ROD, U-BOLTS, HEX BOLTS, NUTS, WASHERS, CHAINLINK FENCING & SCAFFOLDING ASSOCRIES. Presently we are exporting to more than 10 countries as well as domestic market these items. Established with a mission to be a “One Stop Shop” in the steel Industry.

Our Factory is in 170000 Square feet and 130000 square feet constructed area with 400 employees Skilled and Un-skilled.

Other than these items we can fabricate any item as per your sample as well as Drawing. We have a team of fully skilled of Designing, Drawing, Fusibility, Costing, Costing Cutting and new development as per customer’s requirement.

We are certified with IATF – 16949 and ISO 14001: 2015 from TUV. Quality is the utmost constituent of our products as we consider quality as the integral part of our Manufacturing process and not as the routine of final check.

SPRING PIN KIT



SPRING PIN KIT BEST SUITABLE : MERCEDES

SR. NO.	Ref. No.	TYPE	O.E.M.
179	FIL 0413	FRONT	395 320 0645
180	FIL 0414	REAR	395 320 0665

SCAFFOLDING ACCESSORIES



JACK NUT



WALLER PLATE



JACK



WATER STOPPER



UNIVERSAL JACK



U - HEAD JACK



TIE ROD



SPANNER



JACK



WING NUT



RAPID CLUMP



PROP NUT

CHAIN LINK ACCESSORIES



END RAIL CLAMP



SPLIT GATE CORNER



DOOR CATCHER



DOM CUP / TOP CUP



CORNER RAIL CLUMP



BRACE CUP



BRACE BAND



CORNER ELBOW WITH FLAT BAR



TENSION BAND



LINE RAIL CLAMPS



**SINGLE EXTANSION ARM
 LIGHT DUTY WITH RAIL**



**DOUBLE EXTANSION ARM
 LIGHT DUTY WITHOUT RAIL**



EYE BOLT CLOSE TYPE



EYE BOLT OPEN TYPE



TURN BUCKLES



WASHERS

SIZE IN MM	SIZE IN	DIN 125 A	DIN 126	F 436	DIN 434	DIN 9021	DIN 127
	INCHES	FLAT	FLAT	FLAT	SQUARE	FENDER	SPRING
MM 04	1/8"						
MM 05	3/16"						
MM 06	1/4"						
MM 08	5/16"						
MM 10	3/8"						
MM 12	1/2"						
MM 14	9/16"						
MM 16	5/8"						
MM 18	11/16"						
MM 20	3/4"						
MM 22	7/8"						
MM 24	1"						
MM 27	1-1/16"						
MM 30	1-1/8"						
MM 33	1-1/4"						
MM 36	1-3/8"						
MM 39	1-1/2"						
MM 42	1-5/8"						
MM 45	1-3/4"						
MM 48	1-7/8"						
MM 52	2"						
MM 56	2-1/4"						
MM 64	2-1/2"						
MM 72	2-3/4"						
MM 76	3"						
MM 82	3-1/4"						
MM 90	3-1/2"						
MM 100	4"						

PIPE CLUMP



SIZE	WITH RUBBER	WITHOUT RUBBER	2 BOLT CLUMP	3 BOLT CLUMP	CLAVIS HANGER	CHANNEL CLUMP
1/2"						
3/4"						
1"						
1-1/4"						
1-1/2"						
2"						
2-1/2"						
3"						
3-1/2"						
4"						
5"						
6"						
8"						
10"						
12"						
14"						
16"						
18"						
20"						
22"						
24"						
27"						
30"						
36"						

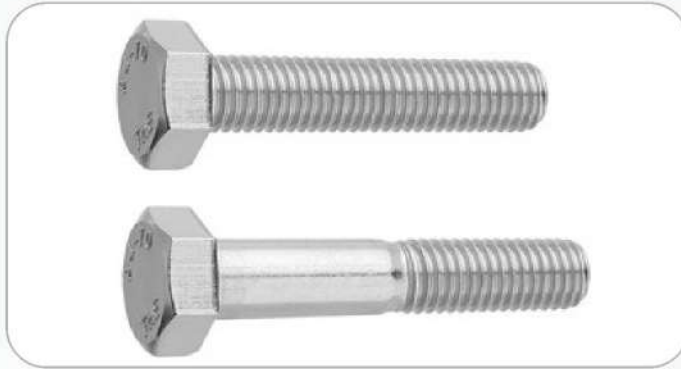

HEX BOLT

LENGTH	LENGTH	MM 06	MM 08	MM 10	MM 12	MM 14	MM 16	MM 18	MM 20	MM 22	MM 24
IN MM	INCHES	1/4"	5/16"	3/8"	1/2"	9/16"	5/8"	11/16"	3/4"	7/8"	1"
MM 12	1/2"										
MM 16	5/8"										
MM 20	3/4"										
MM 25	1"										
MM 30	1-1/4"										
MM 35	1-1/2"										
MM 40	1-1/2"										
MM 45	1-3/4"										
MM 50	2"										
MM 55	2-1/4"										
MM 60	2-1/2"										
MM 65	2-1/2"										
MM 70	2-3/4"										
MM 75	3"										
MM 80	3-1/4"										
MM 90	3-1/2"										
MM 100	4"										
MM 110	4-1/2"										
MM 120	4-3/4"										
MM 125	5"										
MM 130	5-1/4"										
MM 140	5-1/2"										
MM 150	6"										
MM 160	6-1/2"										
MM 170	6-3/4"										
MM 180	7"										
MM 190	7-1/2"										
MM 200	8"										

FINISH: Zinc / Black / Hot Dip / PTFE

GRADES: 4.8 / 8.8 / 10.9 / A3.7B / A325M / SS304 / SS316



HEX NUT

DIA IN MM	IN INCHES	DIN 934	ASTM	ASTM- A	B8/B8M	ASTM A194	DIN 6915
		DIN 555	A 563	A & C	2H/2HM/GR7	GRADE 10S	
MM 06	1/4"						
MM 08	5/16"						
MM 10	3/8"						
MM 12	1/2"						
MM 14	9/16"						
MM 16	5/8"						
MM 18	11/16"						
MM 20	3/4"						
MM 22	7/8"						
MM 24	1"						
MM 27	1-1/16"						
MM 30	1-1/8"						
MM 33	1-1/4"						
MM 36	1-3/8"						
MM 39	1-1/2"						
MM 42	1-5/8"						
MM 45	1-3/4"						
MM 48	1-7/8"						
MM 52	2"						
MM 56	2-1/4"						
MM 64	2-1/2"						
MM 72	2-3/4"						
MM 76	3"						
MM 82	3-1/4"						
MM 90	3-1/2"						
MM 96	3-3/4"						
MM 100	4"						



THREADED ROD

Dia in mm	Dia in inches	GRADE 4.8	ASTM A193B7/B7M	ASTM A320L7	ASTM B 16	B8 / B8M
MM 06	1/4"					
MM 08	5/16"					
MM 10	3/8"					
MM 12	1/2"					
MM 14	9/16"					
MM 16	5/8"					
MM 18	11/16"					
MM 20	3/4"					
MM 22	7/8"					
MM 24	1"					
MM 27	1-1/16"					
MM 30	1-1/8"					
MM 33	1-1/4"					
MM 36	1-3/8"					
MM 39	1-1/2"					
MM 42	1-5/8"					
MM 45	1-3/4"					
MM 48	1-7/8"					
MM 52	2"					
MM 56	2-1/4"					
MM 64	2-1/2"					
MM 72	2-3/4"					
MM 76	3"					
MM 82	3-1/4"					
MM 90	3-1/2"					
MM 96	3-3/4"					
MM 100	4"					

FINISH: Zinc Galv. / Hot Dip Galv.
GRADES: 4.8 / GR55 / A307 / 8.8 / B7 / B7M / L7 / B16 / B8 / B8M



U- BOLT

PIPE SIZE	1/4"	5/16"	3/8"	1/2"	5/8"	3/4"	7/8"	1"
	MM 06	MM 08	MM 10	MM 12	MM 16	MM 20	MM 22	MM 24
1/2"								
3/4"								
1"								
1-1/4"								
1-1/2"								
1-3/4"								
2"								
2-1/4"								
2-1/2"								
3"								
3-1/2"								
4"								
5"								
6"								
8"								
10"								
12"								
14"								
16"								
18"								
20"								
22"								
24"								
27"								
30"								
36"								
42"								

FINISH: Zinc Plated / Hot Dip / PVC
 GRADES: A36/ 8-8/ ASTM A193 B7 S.S.304/ SS316 / Any Special S12E Can be Supply

ANCHOR BOLT

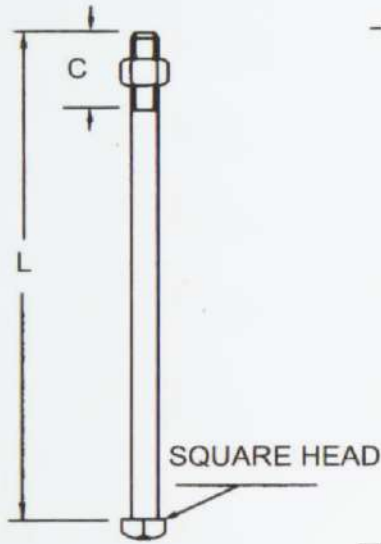

TYPE 1

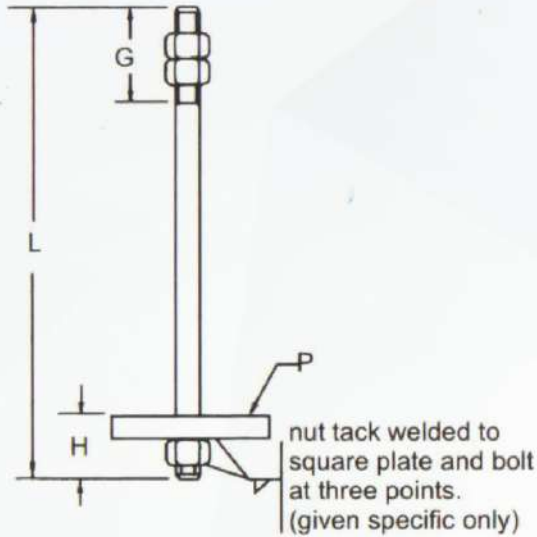

TYPE 2



TYPE 3

Dia in MM	12MM	16MM	20MM	22MM	24MM	27MM	30MM	33MM	36MM	39MM	42MM	45MM	48MM	52MM	56MM	64MM	72MM
Dia in inches	1/2"	5/8"	3/4"	7/8"	1"		1-1/8"	1-1/4"	1-3/8"	1-1/2"	1-5/8"	1-3/4"	1-7/8"	2"	2-1/4"	2-1/2"	2-3/4"
MM 150																	
MM 200																	
MM 250																	
MM 300																	
MM 350																	
MM 400																	
MM 450																	
MM 500																	
MM 550																	
MM 600																	
MM 650																	
MM 700																	
MM 750																	
MM 800																	
MM 900																	
MM 1000																	

FINISH: Self / Zinc / Hot Dip / Galv.
GRADES: A36 / GR55 / A307 / 8.8 / ASTM A193B7 / SS304 / SS316

ANCHOR BOLT

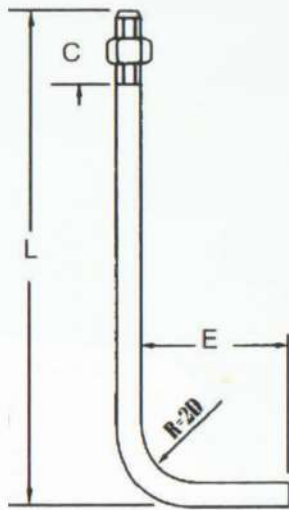

TYPE L

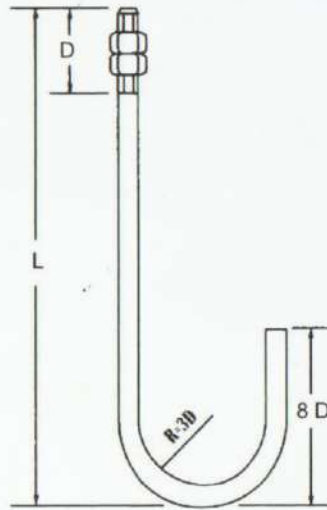

TYPE J

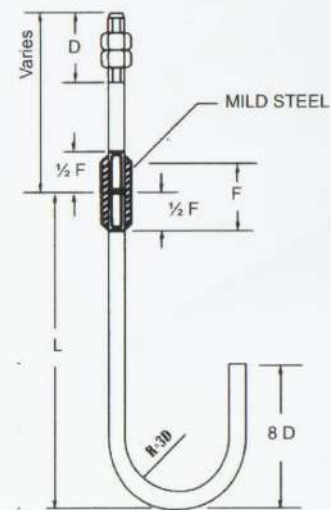

TYPE JE

Dia in MM	12MM	16MM	20MM	22MM	24MM	27MM	30MM	33MM	36MM	39MM	42MM	45MM	48MM	52MM	56MM	64MM	72MM
Dia in inches	1/2"	5/8"	3/4"	7/8"	1"		1-1/8"	1-1/4"	1-3/8"	1-1/2"	1-5/8"	1-3/4"	1-7/8"	2"	2-1/4"	2-1/2"	2-3/4"
MM 150																	
MM 200																	
MM 250																	
MM 300																	
MM 350																	
MM 400																	
MM 450																	
MM 500																	
MM 550																	
MM 600																	
MM 650																	
MM 700																	
MM 750																	
MM 800																	
MM 900																	
MM 1000																	

PLANT & INFRASTRUCTURE



ALUMINIUM HIGH PRESSURE DIE CASTING



- 250 TON PDC MACHINES with auto ladle/auto spray facility Make ZITAI
- 350 TON PDC MACHINES with auto ladle/auto spray facility Make ZITAI
- 420 TON PDC MACHINES with auto ladle/auto spray facility make ZITAI, HMT - BUHLER, SINATEC.
- Component upto 4 Kg

INDUCTION FURNACES MAKE INDUCTOTHERM

Induction Furnace in Operation:



Lifting Magnt & Charger:



AUTOMATED SAND PLANT (MAKE DISA - CAPACITY 20 TONS PER HOUR)



INDUCTION FURNACES MAKE INDUCTOTHERM



PRESS SHOP & POWER COATING PLANT



MACHINE SHOP



DESIGNING

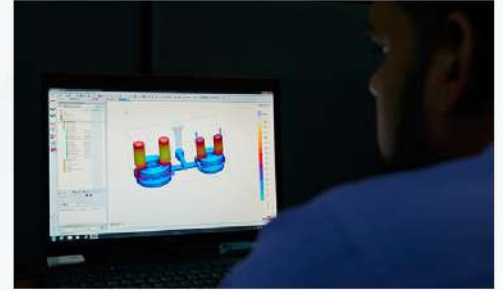
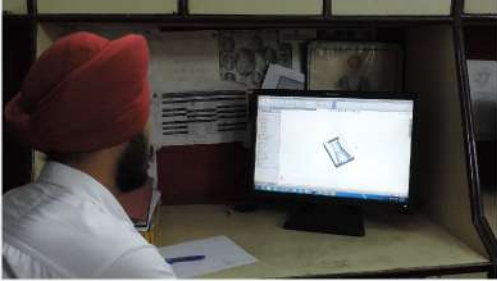

TOOL ROOM



LABORATORY & INSPECTION EQUIPEMENTS





Impregnation & PDI

PDC

Machine shop

Foundry PDI

Design & Development

Core Processing



Foundry

Sand Plant

Admin Block



PERFECT METTCAST LIMITED

Humbran-Mullanpur Road, Ludhiana - 141110. (Pb.) INDIA

E-mail: sales@mettcast.com Web: www.mettcast.com

M: 81466-44778, P: +91 1612871980, 2871982

F: +91 161 2871981